

Part number  
**CSHF 06**



**Brief description:**

female insert, 6 poles + PE, Spring connection contacts SQUICH, 16A, 500V, 6kV, 3, silver plated, size "44.27", CLASS insert series

Product description		Approvals / Standards	
<b>Model</b>	female insert	<b>Reference standard</b>	EN 61984 (2001-11)
<b>Version</b>	SQUICH® Spring connection contacts	<b>Quality mark</b>	EAC
<b>Series</b>	CSH	<b>Conformity</b>	CQC, CE
<b>Product type</b>	with female contacts	<b>General ordering information</b>	
<b>Family</b>	CLASS inserts	<b>EAN13 code</b>	8015747080293
<b>Size</b>	size "44.27"	<b>Tariff number</b>	85369095
<b>N. of poles</b>	6 poles +	<b>Country of origin</b>	Made in EU (IT)
<b>Technical data</b>		<b>ETIM classification</b>	EC000438
<b>Current</b>	16 A (A.C. and D.C.)	<b>Packaging Information</b>	
<b>Voltage</b>	500 V	<b>Packaging length</b>	245,00 mm
<b>Rated impulse withstand voltage</b>	6kV	<b>Packaging height</b>	165,00 mm
<b>Pollution degree</b>	3	<b>Packaging width</b>	215,00 mm
<b>Wire cross-section</b>	0,14 mm <sup>2</sup> - 2,50 mm <sup>2</sup>	<b>Packaging weight</b>	3,06 kg
<b>AWG size</b>	26 - 14	<b>Packaging volume</b>	8,69 dm <sup>3</sup>
<b>Operating temperature range (min, max)</b>	-40°C ... +125°C	<b>Packaging description</b>	Carton box
<b>Contact type</b>	silver plated	<b>Packaging quantity</b>	60 Pcs
<b>Mating cycles</b>	≥ 500	<b>Packaging EAN code</b>	8015747170642
<b>IP degree of protection</b>	IP20 without enclosure; IP65/IP66/IP67/IP68 with enclosure	<b>Sub-packaging length</b>	197,00 mm
<b>PE wire cross-section</b>	0,14 - 4 mm <sup>2</sup> ; AWG 20 - 12	<b>Sub-packaging height</b>	44,00 mm
<b>Tightening torque for PE connection</b>	M4: 1,2 Nm, 10,6 lb.in (Ph2 or 1,0x5,5mm )	<b>Sub-packaging width</b>	113,00 mm
<b>Further technical details</b>		<b>Sub-packaging weight</b>	0,51 kg
<b>Characteristics according to EN 61984</b>	16A 500V 6kV 3; 16A 400/690V 6kV 2	<b>Sub-packaging volume</b>	0,98 dm <sup>3</sup>
<b>Insulation resistance</b>	≥ 10 GΩ	<b>Sub-packaging description</b>	Carton
<b>Contact resistance</b>	≤ 0,3 mΩ	<b>Sub-packaging quantity</b>	10 Pcs
<b>Rated voltage according to UL/CSA</b>	600V	<b>Sub-packaging EAN barcode</b>	8015747170659
<b>UL 94 flammability rating</b>	V-0		
<b>Main contacts stripping length</b>	7 mm		
<b>Torque for main contact</b>	M3: 0.5 Nm; 4.4 lb.in (Ph0 or 0,8x4mm )		
<b>Tightening torque for fixing screws</b>	M3: 0.5 Nm; 4.4 lb.in (Ph1 or 0.8x4 mm)		
<b>Weight</b>	51,00 g		

# Part number CSHF 06



Catalogue drawings

Catalogue drawings

dimensions in mm

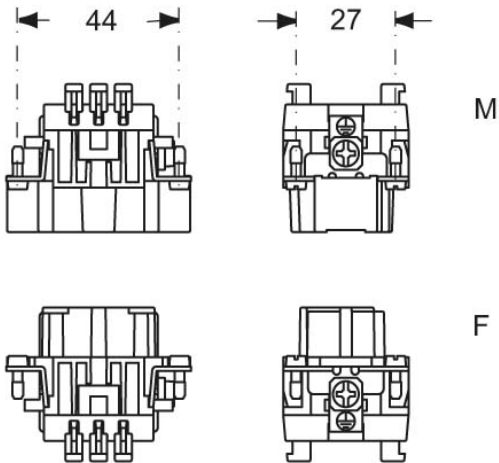

contacts side (front view)

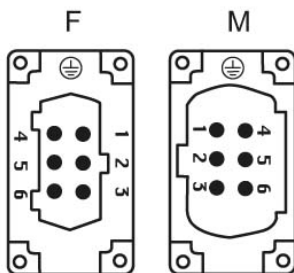
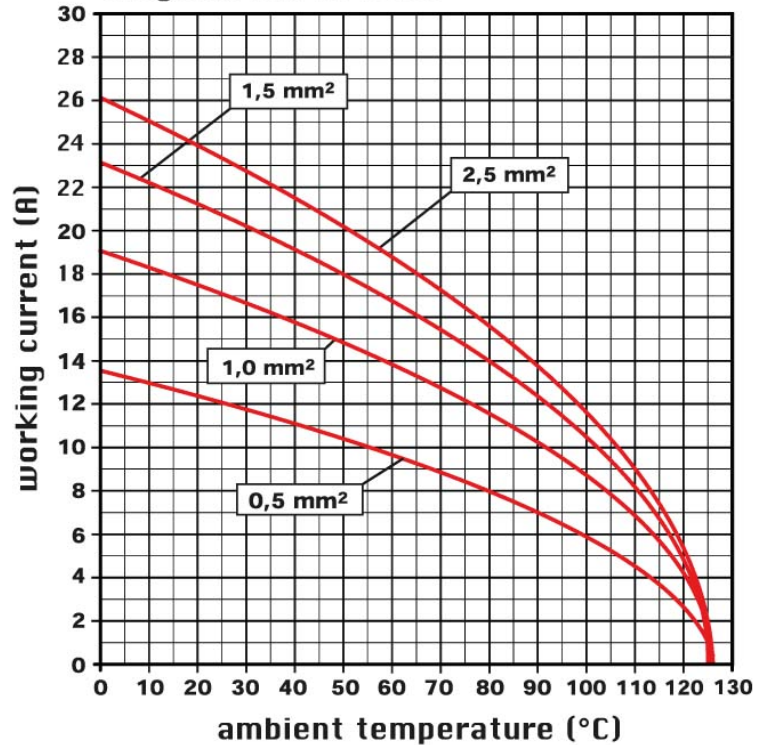

diagram CSH 06 poles



## Notes

CSHF/M 06

- characteristics according to EN 61984:

16A 500V 6kV 3

16A 400/690V 6kV 2

- rated voltage according to UL/CSA: 600V

- insulation resistance: > 10 GOhm

- ambient temperature limit: -40 °C ... +125 °C

- are made of self-extinguishing thermoplastic resin UL 94 V0

- mechanical life: > 500 cycles

- contact resistance: < 3 mOhm

- enclosures: size "44.27":

C-TYPE IP65/IP66

C7 IP67 stainless steel lever

V-TYPE IP65/IP66

stainless steel lever

T-TYPE IP65 insulating

JEI zinc-plated steel lever

BIG hoods

W-TYPE aggressive environments

EMC

central lever

IP68

- panel supports:

COB

actuator button connections

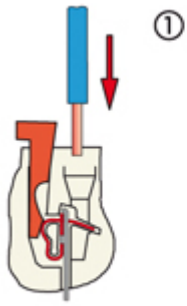

①

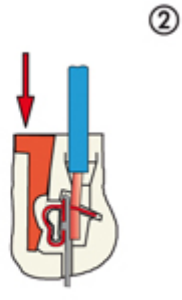

②

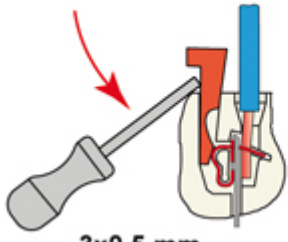

**3x0,5 mm**

Reopening

---